

ATTENTION :

WARNING :

Choisir les pièces détachées en fonction du type de la cuve. La cuve complète ou le cutter complet étant parfaitement interchangeable, dans tous les cas choisir respectivement les repères 5 ou 1.

Choose the spare parts in accordance with the bowl type. As the complete bowl or the cutter attachment are fully interchangeable, for all types choose respectively item 5 or 1.

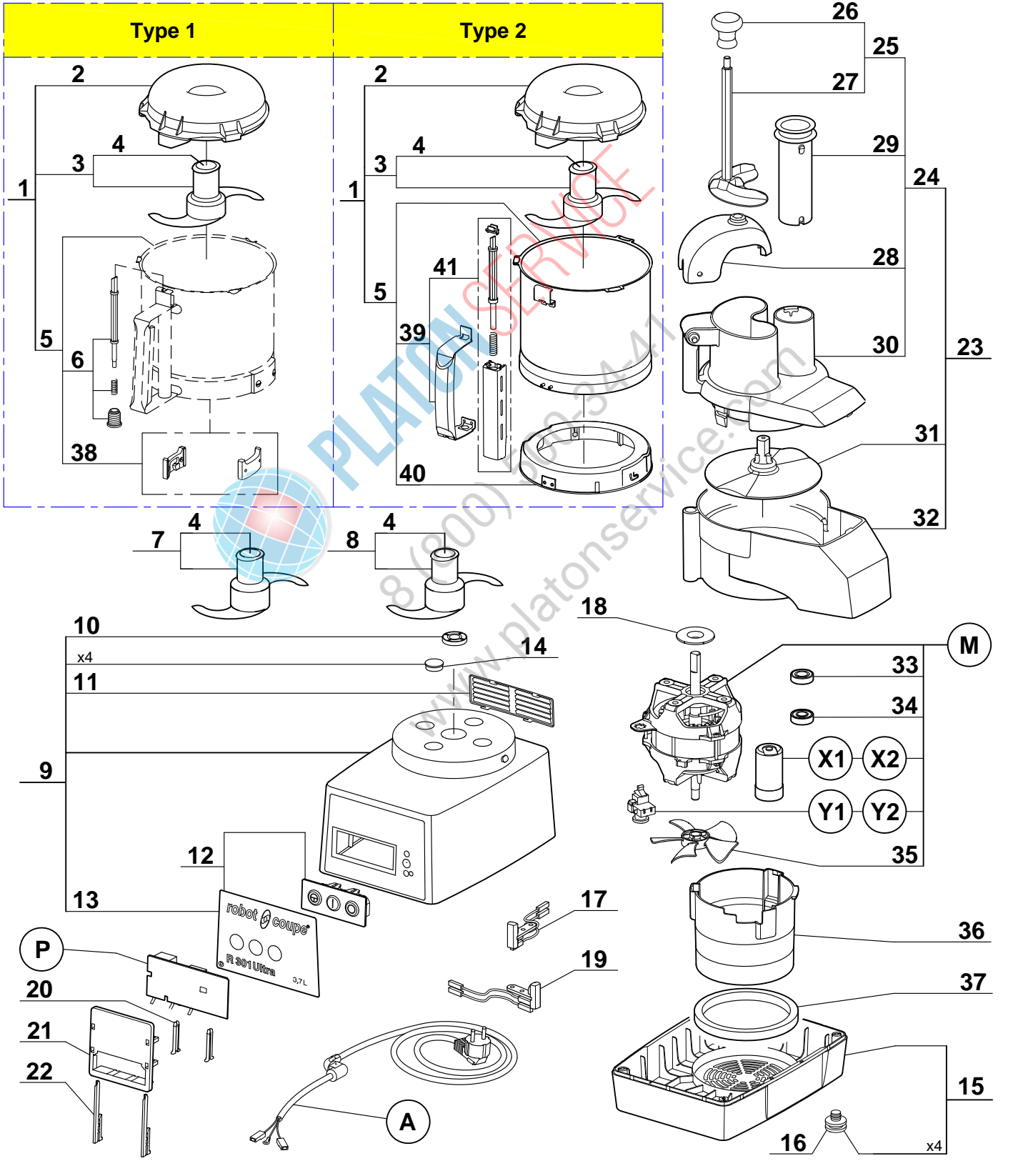
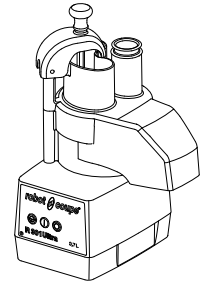

Index	Pièce / Part	Désignation	Description
1	27 278	CUTTER COMPLET	CUTTER ATTACHEMENT
2	117 395	COUVERCLE CUTTER	CUTTER LID
3	27 286	COUPEAU LISSE	STRAIGHT BLADE
4	104 147	CAPUCHON COUPEAU	BLADE CAP
5	39 759	ENS. CUVE CUTTER	CUTTER BOWL ASSEMBLY
6	39 228	ENS. TIGE SECURITE	SAFETY ROD ASSEMBLY
7	27 287	COUPEAU DENTE	FINE SERRATED BLADE
8	27 288	COUPEAU CRANTE	SERRATED BLADE
9	39 317	ENS. SUPPORT MOTEUR	MOTOR SUPPORT ASSEMBLY
10	501 010	BAGUE ETANCHEITE	SHAFT SEAL
11	104 122	GRILLE VENTILATION	VENTILATION GRID
12	39 293	ENS. TABLEAU COMMANDE	CONTROL PANEL ASSEMBLY
13	407 834	PLAQUE FRONTALE	FRONT PLATE
14	104 121	CAPSULE CACHE VIS	BOLT COVER
15	39 288	ENS. SOCLE	BASE ASSEMBLY
16	101 082	PIED	FOOT
17	29 356	INTERRUPTEUR SECURITE COUPE-LEGUMES	VEGETABLE SLICER SAFETY SWITCH
18	104 078	CENTREUR MOTEUR	MOTOR CENTRING
19	29 451	INTERRUPTEUR SECURITE CUTTER	CUTTER SAFETY SWITCH
20	102 913	CLAVETTE PLASTRON	PANEL KEY
21	102 911	SUPPORT PLATINE	CONTROL BOARD SUPPORT
22	117 703	CLAVETTE FIXE PLATINE	CONTROL BOARD KEY
23	27 295	ENS. COUPE-LEGUMES	VEGETABLE SLICER ASSEMBLY
24	39 287	ENS. COUVERCLE COUPE-LEGUMES	VEGETABLE SLICER LID ASSEMBLY
25	29 880	ENS. POUSSOIR LEGUMES	VEGETABLE PUSHER ASSEMBLY
26	102 021	POIGNEE	HANDLE KNOB
27	103 703	POUSSOIR LEGUMES	VEGETABLE PUSHER
28	104 922	GUIDE POUSSOIR	PUSHER GUIDE
29	118 324	POUSSOIR CAROTTES	ROUND PUSHER
30	104 919	COUVERCLE COUPE-LEGUMES	VEGETABLE SLICER LID
31	104 921	DISQUE EVACUATEUR	SLING PLATE
32	104 918	CUVE COUPE-LEGUMES	VEGETABLE SLICER BOWL
33	504 229	ROULEMENT MOTEUR SUPERIEUR 6002 2RS	UPPER BALL-BEARING 6002 2RS
34	600 457	ROULEMENT MOTEUR INFERIEUR 6201 2RS	LOWER BALL-BEARING 6201 2RS
35	117 610	VENTILATEUR MOTEUR	MOTOR FAN
36	104 110	CONDUIT VENTILATION	VENTILATION BAFFLE
37	101 099	TAMPON AMORTISSEUR	ABSORBER
38	29 081	ENS. PLAQUETTE	LOCKING PLATE ASSEMBLY
39	39 752	ENS. POIGNEE CUVE	BOWL HANDLE ASSEMBLY
40	39 797	ENS. RONDELLE D'ACCROCHAGE	LOCKING WASHER ASSEMBLY
41	39 751	ENS. TIGE SECURITE	SAFETY ROD ASSEMBLY

Index	Désignation	Description
A	CABLE D'ALIMENTATION	POWER CORD
M	MOTEUR	MOTOR
P	CARTE DE COMMANDE	CONTROL BOARD
X	CONDENSATEUR DE DEMARRAGE	STARTING CAPACITOR
Y	RELAIS DEMARRAGE MOTEUR	MOTOR STARTING RELAY

Machine	Voltage	A	M	P	X1	X2	Y1	Y2					
22 377 UK	240/50/1	504 275	3 074	103 693	600 018		500 289						
2 447 UK													
2 540 Pack 4D UK													
22 378 Aust		504 278											
2 542 Pack 4D Aust													
22 379 DK	230/50/1	504 276							3 153	103 693	600 018		504 674
2 550 DK													
22 403 CH		504 292											
2 418 CH													
2 417 Pack 4D CH													
22 493 ZAF		39 601											
2 497 Pack 4D ZAF													
22 375		220/60/1	504 275	3 153	103 693	600 018		504 674					
2 547													
2 546 Pack 4D FR			39 604										
2 545 Pack 3D ALL													
2 544 Pack 4D SWE													
2 548 Pack 5D OST													
22 163 SAU	504 274												
2 494 SAU													
22 534 BRA	504 274												
3 554 Pack 4D BRA													
3 548 BRA													
22 380	120/60/1	504 277	3 076	103 692	603 669	600 018	500 289	504 674					
2 543													
22 381	120/60/1	504 277	3 076	103 692	603 669	600 018	500 289	504 674					
2 541													



**CHOISIR X1 - Y1 POUR LES MOTEURS A FIL VIOLET ET X2 - Y2 POUR LES MOTEURS A FIL BLEU.
 CHOOSE X1 - X2 FOR MOTORS WITH PURPLE WIRE AND X2 - Y2 FOR MOTORS WITH BLUE WIRE.**